

DEAN®

DECATHLON D60

VALUE PERFORMANCE GAS FRYERS



Engineered to meet the demands of high-production kitchens, Decathlon fryers offer exceptional cooking capacity and rapid recovery times. Their generous oil capacity supports everything from high-turnover items like French fries to larger menu offerings that require expanded frying space.

Energy Efficiency that Translates to Savings: The Thermo-Tube design provides an additional 2" of tube height and 36% more heat transfer surface area. This reduces the heat per square inch on the oil by 22%, for more efficient heat transfer and longer lasting oil life.

Durable Construction: Constructed with a stainless steel frypot, door, and cabinet sides, the Decathlon is built to withstand the rigors of a commercial kitchen. Its robust design ensures longevity and ease of cleaning.

Precise Heat Control. Prolonged Oil Life: Accurate temperature control during heat-up and recovery protects oil from excessive high-heat exposure, helping extend its life and maintain food quality.

Cleaner Oil. Better Food: The wide cold zone traps sediment below the cooking area, preserving oil quality and ensuring consistently great-tasting food.

Project _____

Item _____

Quantity _____ CSI Section 11400 _____

Approval _____ Date _____

MODELS

D160G

SCFD260G

SCFD360G

SCFD460G

OPTIONS / ADD-ONS

Casters (D160 only)

Spreader cabinet

External oil discharge (front or rear)

CONTROLLERS

Thermatron (standard)

SPECIFICATIONS	
OIL CAPACITY	75-lbs. (37 liters) PER FRYPOT
FRYING AREA	18" x 18" x 3.75" (46 x 46 x 9.5 CM) PER FRYPOT
POT TYPE	Tube
GAS TYPE	Natural Gas Propane Mix
PLUG	NEMA 5-15P
POWER	150,000 BTU/HR PER FRYPOT
STANDARD FEATURES	<ul style="list-style-type: none"> Thermo-Tube heat-transfer design Wide cold zone RTD 1° compensating temperature probe Drain safety switch (filter models only) Combination gas valve with regulator Melt cycle and boil-out mode Stainless steel frypot, door, and cabinet sides
STANDARD ACCESSORIES	<ul style="list-style-type: none"> (2) Twin baskets PER FRYPOT Basket hangers Basket support racks 6"-7" (15-17 cm) adjustable steel legs (D160) Casters (all filter models)

Liter conversions are for liquid shortening @ 70° F



REVISED SPRING 2026

Frymaster®

318-865-1711
1-800-221-4583
info@frymaster.com

8700 Line Avenue
Shreveport, LA 71106-6800, USA
FRYMASTER.COM

WELBILT®
an All Group Company

DECATHLON D60

DIMENSIONS	MODEL	OIL CAPACITY PER FRYPOT	OVERALL SIZE			DRAIN HEIGHT
			WIDTH	DEPTH	HEIGHT	
	D160G	75-lbs. (37 liters)	20" (51.8 cm)	38.1" (96.7 cm)	45.9" (116.7 cm)	19.75" (50 cm)
	SCFD260G		40" (102.6 cm)	38.3" (97.2 cm)	46.3" (117.7 cm)	
	SCFD360G		60" (153.4 cm)			
	SCFD460G		80" (204.2 cm)			

CRATED	MODEL	WEIGHT	WIDTH	DEPTH	HEIGHT	CU. FT.	CLASS
SCFD260G	417-lbs. (189 kg)	53" (134.6 cm)	68	77.5			
SCFD360G	815-lbs. (370 kg)	66" (167.6 cm)	88				
SCFD460G	1,295-lbs. (587 kg)	83" (210.8 cm)	111				

Information is APPROXIMATE and may vary at time of shipment due to options/add-ons

GAS REQ.	GAS TYPE	INC. GAS PRESSURE	POWER
	NATURAL GAS	6" W.C.—14" W.C.	
	LIQUID PROPANE	9" W.C.—14" W.C.	
	MIXED GAS	11" W.C.—14" W.C.	

150,000 BTU/HR (44 KW) PER FRYPOT

ELECTRICAL REQ.	REGION	CONTROLS PER FRYPOT	FILTER PER FRYPOT	BASKET LIFTS PER FRYPOT
	DOMESTIC	1 A	8 A	—
	EXPORT	1 A	4 A	—

Plug is optional on all units shipped with a cord. Canada is an exception; and cord, where available, must have a plug attached.

Cord length and gauge as well as plug type and style available vary depending upon fryer model, voltage, kW, destination, and customer specifications. Consult local codes or contact factory.

GAS CONNECTION	
FRYPOTS	SIZE NPT
1	(1) 3/4"
2-4	(1) 1"

CLEARANCE INFORMATION

Front: 36" (91.4 cm) for servicing and proper operation.

Sides & Rear: 6" (15.2 cm) from any combustible material.

VENTILATION REQUIREMENTS

When installing any fryer, NFPA Standard No. 96 must be strictly followed.

NOTES

- DO NOT CURB MOUNT

HOW TO SPECIFY

Electric or gas, gas type (if applicable), pot type, energy output, oil capacity, number of frypots, controller, filtration type, and optional feature(s).

- Elevation:** Must specify elevation if between 2,000 – 6,000 ft. (Fryer may not perform at optimum levels above 6,000 ft.)

WARRANTY

Frypot

1st year: Parts + Labor
2nd - 10th years: Parts Only

Controller

1 year: Parts + Labor

All Other Parts

1 year: Parts + Labor

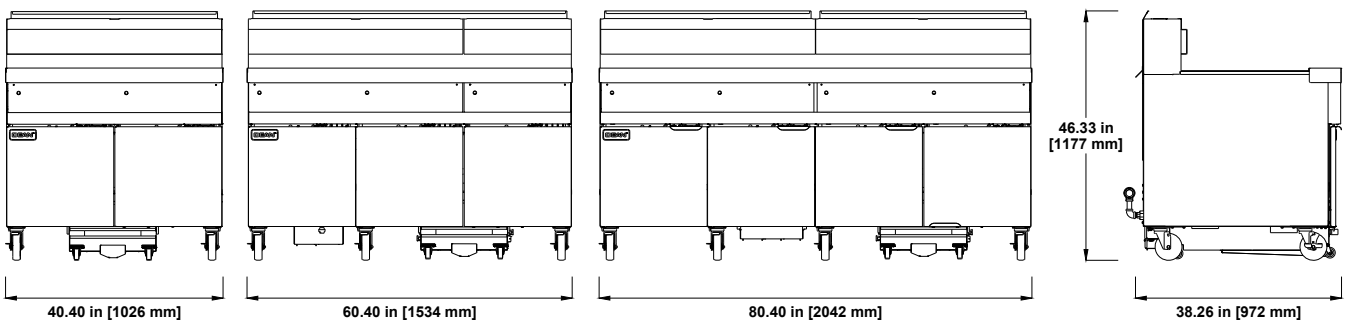
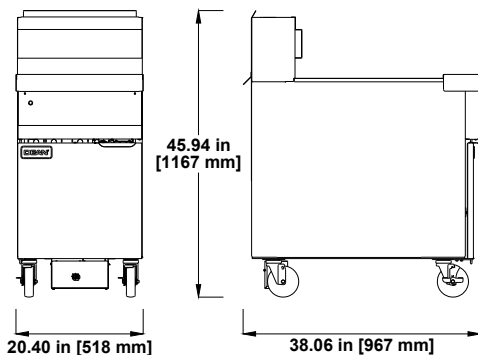

Frymaster reserves the right to make changes to the design or specifications without prior notice.

REVISED SPRING 2026

Frymaster

318-865-1711
1-800-221-4583
info@frymaster.com

8700 Line Avenue
Shreveport, LA 71106-6800, USA
FRYMASTER.COM

WELBILT
an All Group Company