



VEGETABLE PREPARATION MACHINE CA-31 120/60/1

Production up to 450 kg.



P/N 1050702



SALES DESCRIPTION

Single-speed motor block + regular hopper.

A perfect cut

- ✓ High precision adjustments to obtain a uniform and excellent-quality cut.
- ✓ It can be fitted with a wide range of discs and grids of the highest cutting quality. Combining these accessories together to obtain more than 70 different types of cuts and grating grades.

Built to last

- ✓ Made from stainless steel and food-grade materials of the highest quality: stainless steel motor block and food-grade aluminium head.
- ✓ High power asynchronous motor.

Maximum comfort for the user

- ✓ Ergonomic design: product sliced in one single movement.
- ✓ Lateral product output: requires less space on the worktop and guides the product, avoiding splashes.
- ✓ The electronic command panel is very intuitive.

Maintenance, safety, hygiene

- ✓ Lever and lid easily removable for cleaning purposes.
- ✓ Combination of safety systems: head, cover, power switch.
- ✓ Appliance certified by NSF International (regulations on hygiene, cleaning and materials suitable for contact with foods).
- ✓ 100% tested.

INCLUDES

- ✓ 1 speed motor block.
- ✓ Regular hopper.

OPTIONAL

- Long vegetable attachment.

ACCESSORIES

- | | |
|---|--|
| <input type="checkbox"/> FCC curved slicing discs | <input type="checkbox"/> Disc and grid holder |
| <input type="checkbox"/> FCO rippled slicing discs | <input type="checkbox"/> Stand-trolley |
| <input type="checkbox"/> FFC chipping grids | <input type="checkbox"/> Quick Cleaner: grid cleaners |
| <input type="checkbox"/> FMC dicing grids | <input type="checkbox"/> FC slicing discs |
| <input type="checkbox"/> FCE julienne discs | <input type="checkbox"/> SH shredding & grating discs |
| <input type="checkbox"/> Long vegetable attachment | <input type="checkbox"/> Déli-cut cutting kit - Heavy Duty |
| <input type="checkbox"/> Disc and grid packs - Heavy Duty | <input type="checkbox"/> Universal grid cleaner QC-U |

SPECIFICATIONS

Hourly production: 150 kg - 450 kg

Inlet opening: 136 cm²

Disc diameter: 205 mm

Motor speed: 365 rpm

Loading

Electrical supply: 120 V / 60 Hz / 1~ (4.3 A)

Plug: USA (NEMA 5-15P / 2P+G)

Noise level (1m.): <70 dB(A)

Background noise: 32 dB(A)

External dimensions (W x D x H)

Width: 389 mm

Depth: 405 mm

Height: 544 mm

Net weight: 23 kg

Crated dimensions

435 x 430 x 600 mm

Volume Packed: 0.11 m³

Gross weight: 27 kg

DYNAMIC PREPARATION
COMMERCIAL VEGETABLE PREPARATION MACHINES



SAMMIC, S.L. · Basarte, 1
20720 AZKOITIA (Gipuzkoa) · SPAIN

product sheet
updated 18/12/2025



VEGETABLE PREPARATION MACHINE CA-31 120/60/1

Production up to 450 kg.



P/N 1050702

DYNAMIC PREPARATION
COMMERCIAL VEGETABLE PREPARATION MACHINES

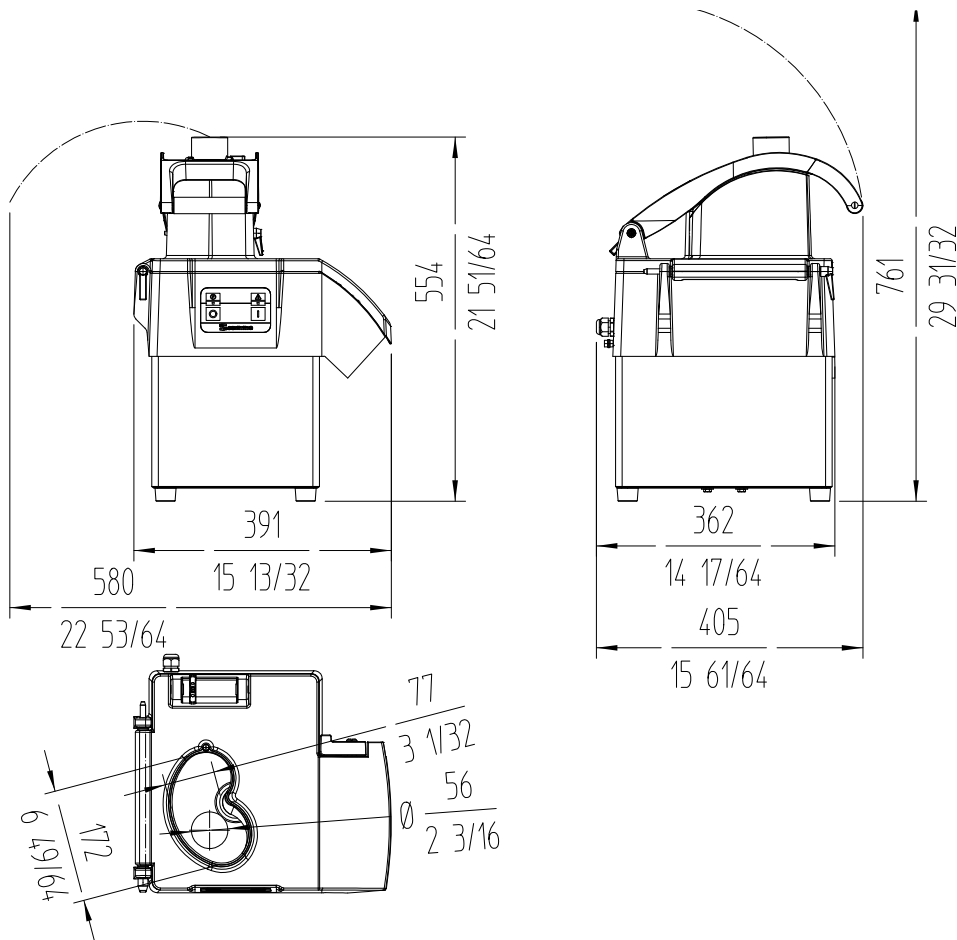

sammic | sammic.com
Food Service Equipment Manufacturer

Polígono Basarte, 1. phone +34 943 15 72 36
 20720 Azkoitia, Spain sales@sammic.com



Project	Date
Item	Qty
Approved	

product sheet
updated 18/12/2025