



IMMERSION BLENDER XM-22 120/50-60/1

Professional immersion blender. 300 W.



P/N 3030758



DYNAMIC PREPARATION
COMMERCIAL HAND BLENDERS

SALES DESCRIPTION

- ✓ Variable speed motor block.
- ✓ 300 mm detachable arm.
- ✓ Designed for continuous use in recipients of up to 15 l.

All-in-one

- ✓ Professional hand blender designed for carrying out different preparations without the need for add-on tools.
- ✓ Professional Y-blade, made from tempered steel and with a long-duration cutting edge.
- ✓ Vario-speed: variable speed.
- ✓ Smooth Control: smart speed control. The new SmoothControl system provides a faster response and better stability to the machine. It also improves the start-up under load and limits over-acceleration when removing the machine and in no-load situations.
- ✓ Designed to work in recipients of up to 15 l.

Maximum comfort for the user

- ✓ Compact design: logical and manageable size.
- ✓ Ergo-design & bi-mat-grip: external casing made in two materials for an ergonomic hold. Anti-slip grip. Optimum inclination of handle, minimising fatigue.
- ✓ Click-on-arm: detachable arm with fast and secure closure.
- ✓ Hood designed to avoid splashes.
- ✓ Intuitive use: very simple operation. Warning light when the machine is connected to the mains.

Built to last

- ✓ Professional performance: capable of carrying out prolonged work without the casing overheating.
- ✓ Life-plus: equipped with a motor which has passed all of the most demanding usage tests.

- ✓ Studied geometry: casing designed to avoid rolling and falling.
- ✓ Ultra-durable arms designed to stand high temperatures in operation.
- ✓ Easy to clean: detachable, dishwasher safe arm.
- ✓ Approved by NSF: guaranteed safety and hygiene.

INCLUDES

- ✓ Variable speed motor block.
- ✓ MA-22 mixer arm.
- ✓ Wall mount.

OPTIONAL

- MA-21 mixer arm.
- Whisk BA-20.

ACCESSORIES

- Motor unit MM-20V
- Whisk BA-20
- Mixer arms MA-20

SPECIFICATIONS

Total loading: 300 W
 Maximum recipient capacity: 15 l
 Maximum working depth: 203 mm
 Motor speed: 1500 - 15000 rpm
 Blade diameter: 50 mm
 Blade guard diameter: 82 mm
 Electrical supply: 120 V / 50-60 Hz / 1~ (2,6 A)
 Plug: USA (NEMA 5-15P / 2P+G)

Length

Liquidising arm length: 300 mm
 Total length: 564 mm
 Net weight: 2.39 kg
 Noise level (1m.): <80 dB(A)

Crated dimensions
 440 x 375 x 105 mm
 Gross weight: 3.25 kg



IDDSI
 International Dysphagia Diet
 Standardisation Initiative



IMMERSION BLENDER XM-22 120/50-60/1

Professional immersion blender. 300 W.



P/N 3030758

DYNAMIC PREPARATION
COMMERCIAL HAND BLENDERS

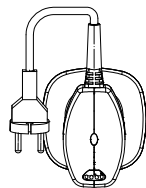
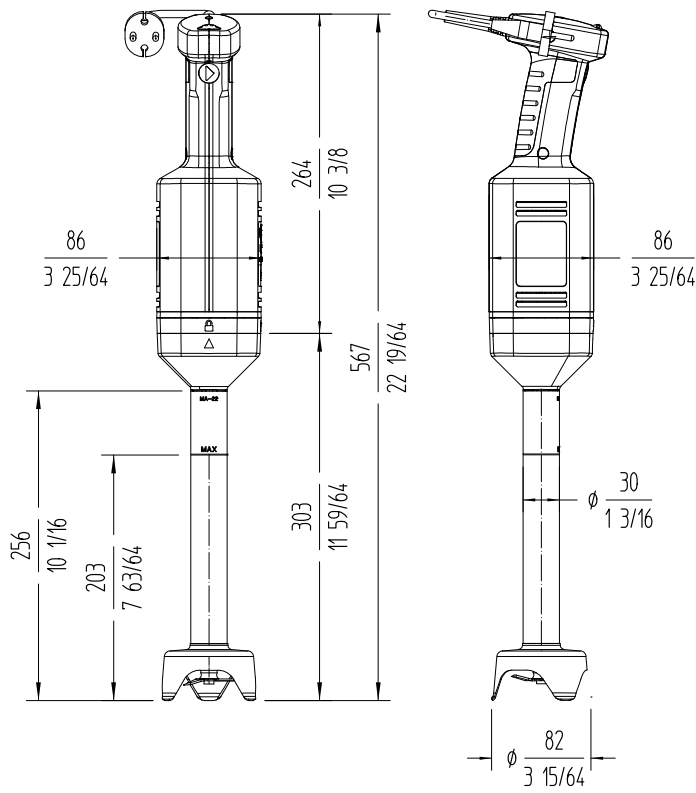

sammic | sammic.com
Food Service Equipment Manufacturer

Polígono Basarte, 1. phone +34 943 15 72 36
 20720 Azkoitia, Spain sales@sammic.com



Project	Date
Item	Qty
Approved	

product sheet
updated 03/12/2025