



IP 50 XP BA  
IP 80 XP BA  
IP 120 XP BA  
IP 180 XP BA

Meat mixers, floor



- Double paddle mixers allow for a fast, homogenous yet gentle mix of a variety of products, from sausage meat to potato salad, coleslaw and sandwich fillings - with great sales appeal and longer shelf-life
- Complete stainless steel construction
- Forward and reverse mixing action allows for more control over the most delicate products
- Paddles are easily removed for cleaning
- Tilting tub for easy product discharge and cleaning

### Features

#### Technical

- Completely made from stainless steel.
- Stainless steel paddles for a thorough mixing and a faster kneading.
- Stainless steel tub tilts for easy product emptying
- Fast cleaning and maintenance

#### Safety

- A safety interlock stops the machine when opening the lid.
- Overload and no volt release protection

#### Sanitary

- Removable paddles for an easy and accurate cleaning.

### Specifications

**Motor IP 50-80:** 1.5 Hp (1100W), fan-cooled.

**Motor IP 120:** 3 Hp (2250W), fan-cooled.

**Motor IP 180:** 3 Hp (2250W), fan-cooled.

**Electrical IP 50-80:** 220-240V AC, 60Hz, 1-Phase, 3A

**Electrical IP 120:** 220-240V AC, 60Hz, 3-Phase, 4.5A

**Electrical IP 180:** 220-240V AC, 60Hz, 3-Phase, 4.5A

**Plug and Cord:** Attached, flexible, 3 wire or 4 wire (3PH+1G) SJT 14 AWG, 6'4" long cord.

IP 50-80: NEMA 6-15 P

IP 120-180: 3Phase hardwired, NEMA15-20 P

#### Controls:

ON/OFF/REV stainless steel keypad, IP 67 waterproof protection.

No voltage release.

Use 5 min. ON / 30 min. OFF



Certified to UL Standard 763  
 Certified to CSA Standard C22.2

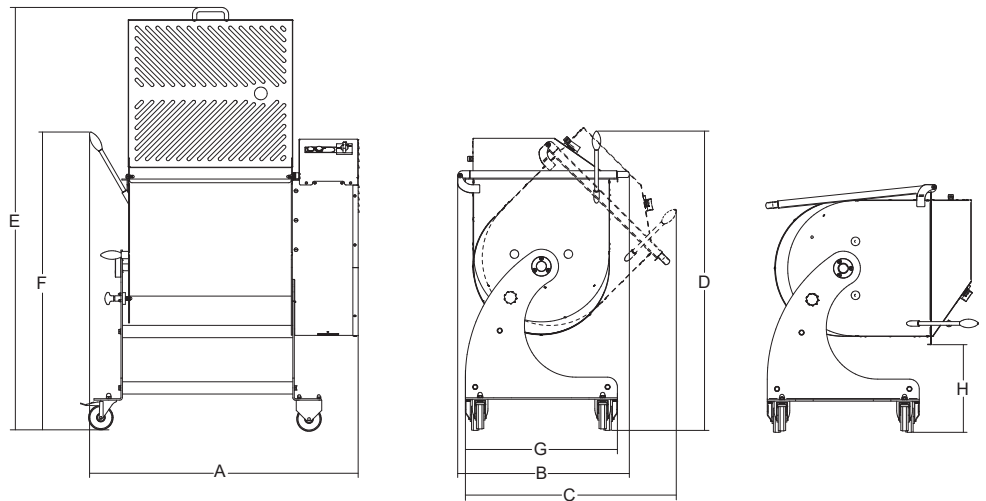

	Power	Power source	Tank dimensions	Capacity	Tank dimensions								Net weight	Shipping	Gross weight
	watt/Hp	+/- 10%			A	B	C	D	E	F	G	H			
<b>IP 50 XP BA</b>	1100/1.5	220-240V, 60Hz, 3A, 1-ph	16 <sup>17/32</sup> " x 19 <sup>11/16</sup> "	93	31 <sup>57/64</sup> "	24 <sup>51/64</sup> "	28 <sup>47/64</sup> "	41 <sup>27/32</sup> "	65 <sup>15/32</sup> "	48 <sup>1/32</sup> "	19 <sup>11/16</sup> "	18 <sup>27/64</sup> "	187	32" x 48" x 60"	240
<b>IP 80 XP BA</b>	1100/1.5	220-240V, 60Hz, 3A, 1-ph	24 <sup>13/32</sup> " x 19 <sup>11/16</sup> "	116,2	41 <sup>7/32</sup> "	24 <sup>51/64</sup> "	28 <sup>47/64</sup> "	41 <sup>27/32</sup> "	65 <sup>15/32</sup> "	48 <sup>1/32</sup> "	19 <sup>11/16</sup> "	18 <sup>27/64</sup> "	198	32" x 48" x 60"	242
<b>IP 120 XP BA</b>	2250/3	220-240V, 60Hz, 4.5A, 3-ph	25 <sup>43/64</sup> " x 21 <sup>21/32</sup> "	171	43 <sup>5/32</sup> "	27 <sup>9/16</sup> "	33 <sup>21/32</sup> "	48 <sup>5/64</sup> "	67 <sup>19/32</sup> "	47 <sup>19/32</sup> "	24 <sup>13/32</sup> "	14 <sup>1/16</sup> "	304	58" x 30" x 52"	380
<b>IP 180 XP BA</b>	2250/3	220-240V, 60Hz, 4.5A, 3-ph	39 <sup>11/64</sup> " x 21 <sup>21/32</sup> "	264	55 <sup>63/64</sup> "	27 <sup>9/16</sup> "	33 <sup>21/32</sup> "	48 <sup>5/64</sup> "	67 <sup>19/32</sup> "	47 <sup>19/32</sup> "	24 <sup>13/32</sup> "	14 <sup>1/16</sup> "	335	58" x 30" x 52"	420