



IMMERSION BLENDER & WHISK COMBO MB-31 120/50-60/1 USA

Professional hand blender and beater. 400 W.



P/N 3030801



DYNAMIC PREPARATION
COMMERCIAL HAND BLENDERS

SALES DESCRIPTION

- ✓ Variable speed motor block.
- ✓ 306 mm detachable mixer arm designed for continuous use in recipients of up to 30 l.
- ✓ Whisk with capacity for 2 to 50 egg whites.

All-in-one

- ✓ Professional hand blender and beater.
- ✓ Professional hand blender designed for carrying out different preparations without the need for add-on tools.
- ✓ Professional Y-blade, made from tempered steel and with a long-duration cutting edge.
- ✓ Vario-speed: variable speed.
- ✓ Mixer arm designed to work in recipients of up to 30 litres.
- ✓ Beater with capacity for 2 to 50 egg whites.

Exclusive TiltStop system

- ✓ Your hand blender will stop in case of a fall or excessive tilt from the vertical position.
- ✓ Moreover, it won't initiate unless it's in the correct usage position.
- ✓ This ensures optimal operation and increases the operator's safety at the workplace.

Maximum comfort for the user

- ✓ Compact design: logical and manageable size.
- ✓ Ergo-design & bi-mat-grip: external casing made in two materials for an ergonomic hold. Anti-slip grip. Optimum inclination of handle, minimising fatigue.
- ✓ Click-on-arm: detachable arm with fast and secure closure.
- ✓ Mixer arm hood designed to avoid splashes.
- ✓ Intuitive use: very simple operation. LED warning light in two colours to indicate the status of the machine.

Built to last

- ✓ Professional performance: capable of carrying out prolonged work without the casing overheating.
- ✓ Life-plus: equipped with a motor which has passed all of the most demanding usage tests.

- ✓ Studied geometry: casing designed to avoid rolling and falling.
- ✓ Easy to clean: detachable, dishwasher safe arms. The whisks are detachable and dishwasher safe.
- ✓ Approved by NSF: guaranteed safety and hygiene.

INCLUDES

- ✓ Variable speed motor block.
- ✓ MA-31 mixer arm.
- ✓ Whisk BA-30.
- ✓ Wall mount.

OPTIONAL

- MA-32 mixer arm.
- MA-33 mixer arm.
- "Quick fix" clamp.
- Clamp sliding frame.

ACCESSORIES

- Clamp sliding frame
- Motor unit MM-30V
- Mixer arms MA-30
- Whisk BA-30
- Quick-Fix bowl clamp

SPECIFICATIONS

Total loading: 400 W
Electrical supply: 120 V / 50-60 Hz / 1~ (3.5 A)
Plug: USA (NEMA 5-15P / 2P+G)

Liquidiser function

Maximum recipient capacity: 30 l
Maximum working depth: 207.3 mm
Motor speed: 1500 - 12000 rpm
Blade diameter: 55 mm
Blade guard diameter: 92.2 mm
Liquidising arm length: 306 mm
Total length: 615 mm

Whisk function

Motor speed: 200 - 1500 rpm
Capacity (egg whites): 2 - 50
Revolving arm length: 396 mm
Total length (with revolving arm): 704 mm
Net weight: 4.61 kg
Noise level (1m.): <80 dB(A)
Crated dimensions
455 x 475 x 117 mm
Gross weight: 5.6 kg





IMMERSION BLENDER & WHISK COMBO MB-31 120/50-60/1 USA

Professional hand blender and beater. 400 W.



P/N 3030801

DYNAMIC PREPARATION
COMMERCIAL HAND BLENDERS

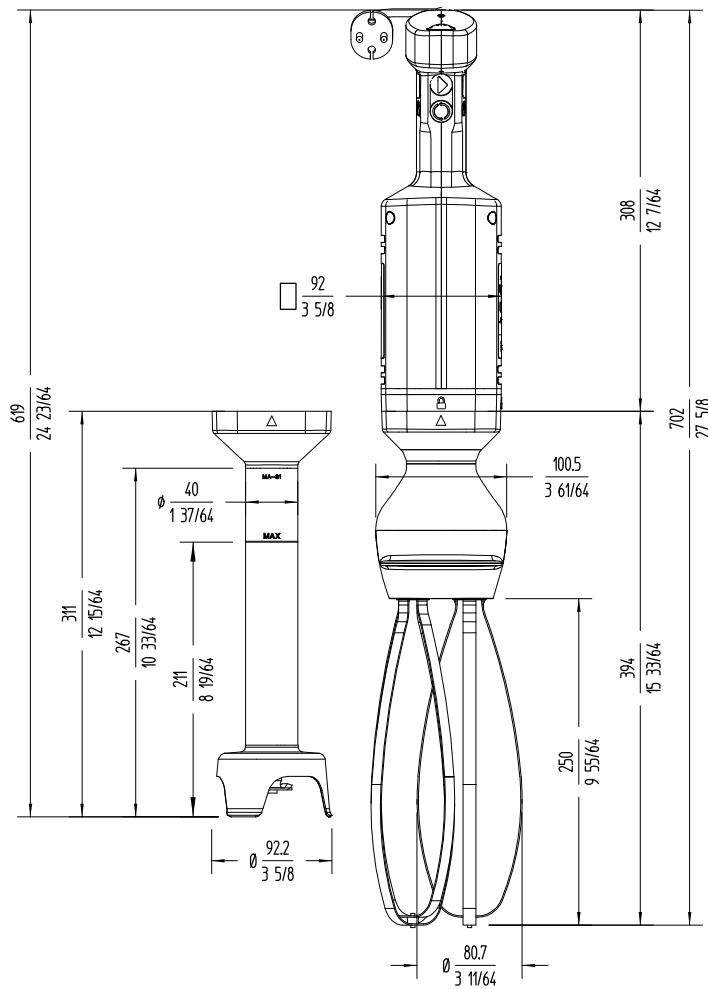

sammic | sammic.com
Food Service Equipment Manufacturer

Polígono Basarte, 1. phone +34 943 15 72 36
20720 Azkoitia, Spain sales@sammic.com



Project	Date
Item	Qty
Approved	

product sheet
updated 16/12/2025