



IMMERSION BLENDER XM-12 120/50-60/1

Compact immersion blender. 240 W.



P/N 3030740



DYNAMIC PREPARATION
COMMERCIAL HAND BLENDERS

SALES DESCRIPTION

- ✓ The most delicate preparations, airy blendings, smooth purees with no need of add-on tools.
- ✓ Designed for continuous use.
- ✓ Ideal for mise en place.
- ✓ Maximum comfort of use in recipients of up to 10 l.

All-in-one

- ✓ Versatility without add-on tools.
- ✓ Tri-blade, professional, made of tempered steel and equipped with a long lasting cutting edge.
- ✓ Vario-speed: adjustable speed.
- ✓ Smooth Control: smart speed control. The new SmoothControl system provides faster response and better stability to the machine. It also improves the start-up under load and limits over-acceleration when removing the machine and in no-load situations.
- ✓ Ideal for mise-en-place and support in service.
- ✓ Designed to work with maximum comfort in recipients of up to 10 l of capacity.
- ✓ In option: shorter MA-11 mixarm.

Maximum comfort for the user

- ✓ Compact design: logical and manageable size.
- ✓ Ergo-design & bi-mat-grip: the external casing, in two materials, allows an ergonomic hold with an anti-slip grip and the handle features optimum inclination to minimise fatigue.
- ✓ Click-on-arm: detachable arm with quick and safe locking.
- ✓ Hood designed to avoid splashes during work.
- ✓ Intuitive use: very simple operation. Includes warning light when the machine is connected to the mains.

Designed to last

- ✓ Professional performance: it is capable of carrying out prolonged work without overheating.

- ✓ Life-plus: equipped with a motor which has passed all of the most demanding usage tests.
- ✓ Studied geometry: casing designed to avoid rolling and falling.
- ✓ Ultra-durable arms designed to stand high temperatures in operation.
- ✓ Easy to clean: the arm can be washed under the tap or in the dishwasher.
- ✓ Approved by NSF: guaranteed safety and hygiene.

INCLUDES

- ✓ Variable speed motor block.
- ✓ MA-12 mixer arm.

OPTIONAL

- MA-11 mixer arm.
- Emulsionizer PRO 1.0.

ACCESSORIES

- Emulsionizer PRO 1.0

SPECIFICATIONS

Total loading: 240 W
 Maximum recipient capacity: 10 l
 Maximum working depth: 148.6 mm
 Motor speed: 1500 - 15000 rpm
 Blade diameter: 44 mm
 Blade guard diameter: 65 mm
 Electrical supply: 120 V / 50-60 Hz / 1~ (1.5 A)
 Plug: USA (NEMA 5-15P / 2P+G)

Length

Liquidising arm length: 223 mm
 Total length: 448 mm
 Net weight: 1.51 kg
 Noise level (1m.): <80 dB(A)
 Crated dimensions
 496 x 80 x 180 mm
 Gross weight: 1.94 kg



IDDSI
 International Dysphagia Diet
 Standardisation Initiative
 GOLD SPONSOR



IMMERSION BLENDER XM-12 120/50-60/1

Compact immersion blender. 240 W.



P/N 3030740

DYNAMIC PREPARATION
COMMERCIAL HAND BLENDERS

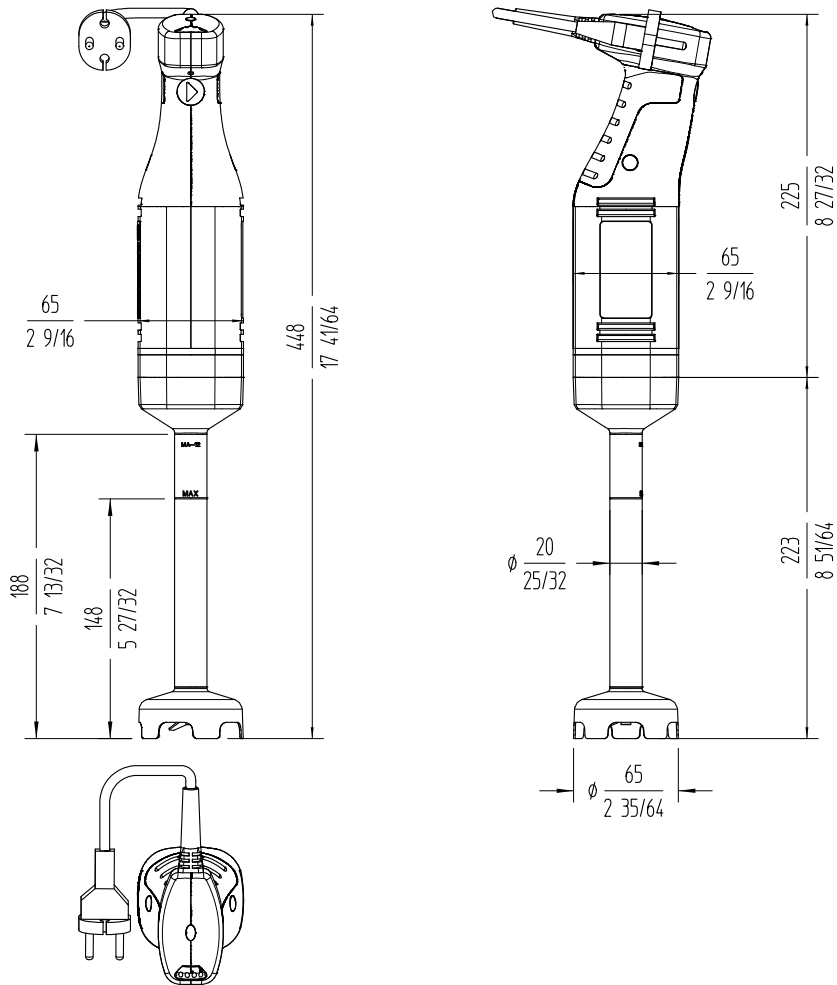

sammic | sammic.com
Food Service Equipment Manufacturer

Polígono Basarte, 1. phone +34 943 15 72 36
20720 Azkoitia, Spain sales@sammic.com



Project	Date
Item	Qty
Approved	

product sheet
updated 19/11/2025