



# COMBI VEGETABLE PREP.-CUTTER CK-24V 2D 120/50-60/1 · 2 DISCS INCLUDED

2-in-1. Compact vegetable slicer + cutter. Adjustable speed with “brushless” technology.

P/N 1050930



DYNAMIC PREPARATION  
FOOD PROCESSOR / VEG PREP COMBI MACHINES



## SALES DESCRIPTION

Compact ULTRA line. Variable speed motor block + vegetable slicer attachment + 4.4 l cutter bowl. “Brushless” technology.

### Equipped with “brushless” technology: powerful and efficient motors

- ✓ Maximum efficiency: maintain the torque throughout the speed range.
- ✓ Exclusive “Force control system”: guarantee of a uniform and high quality result.
- ✓ Lightweight and compact design: they weigh less, they occupy less space.
- ✓ Improved air/water-tightness since no ventilation is required.
- ✓ They generate less noise: improved workplace environment.

### Vegetable slicer function: a perfect cut

- ✓ High precision settings and comprehensive cutter and disc design aimed at obtaining a perfect cut.
- ✓ Gravity Slide System allow to reconstruct the sliced product for storing or presentation purpose.
- ✓ Ejection disc included for the products that require its use.
- ✓ It can be fitted with a wide range of discs and grids of the highest cutting quality.

Combining these accessories together to obtain more than 35 different types of cuts and grating grades.

- ✓ Exclusive “Force control system” to optimise and standardise the cutting of each product: acoustic warning when the motor exceeds the pre-established force.

### Cutter function: efficiency and performance

- ✓ Possibility of programming by time and pulse button.
- ✓ 4.4 lt-bowl equipped with lateral stirrer and high shaft to obtain a bigger production.
- ✓ Transparent lid equipped with hole to add ingredients in use.
- ✓ Lid complete with gasket to avoid product overflowing.
- ✓ Homogeneous and fine mixing result thanks to the lateral stirrers and invert-blade technology.
- ✓ The lateral stirrers avoid product overheating.

- ✓ Very uniform finish due to the movement generated the special position of the cutting edges.
- ✓ Depending on the purpose, the possibility of using optional smooth or perforated blades.
- ✓ Built-in parametrisable programs to obtain the desired texture in seconds and in a standardized way: dense texture, fine texture, pulses (PrecisePulse function).
- ✓ Option to customize programs for recipe standardization.

### Built to last

- ✓ Sturdy construction in food-grade best quality materials.

### Maximum comfort for the user

- ✓ Ergonomic design: product sliced in one single movement.
- ✓ Cutter bowl equipped with ergonomic handle.
- ✓ Lateral product output: requires less space on the worktop and guides the product, avoiding splashes.
- ✓ Adjustable product ejection direction to adapt to the workflow in the preparation area.
- ✓ Advanced control panel that is very intuitive to use and offers all the information at a glance.
- ✓ Recessed cored relief allows for any position in the kitchen, side walls, back wall, light and compact, this machine can fit.
- ✓ Control panel equipped with timer to standardise processes.

### Maintenance, safety, hygiene

- ✓ Lever, lid and bowl are easily removable for cleaning purposes.
- ✓ Stainless steel, dishwasher-safe discs. The removable blades allow for an even more thorough and efficient cleaning.
- ✓ Combination of safety systems: head, cover, bowl, power switch.
- ✓ Complete error warning system.
- ✓ Appliance certified by NSF International (regulations on hygiene, cleaning and materials suitable for contact with foods).
- ✓ 100% tested.

## INCLUDES

- ✓ Variable speed motor block.
- ✓ Vegetable slicer attachment.
- ✓ Cutter bowl with toothed blades.
- ✓ Gravity product expulsion ramp.
- ✓ Ejection disc.
- ✓ FCS-4 slicing disc (4 mm).
- ✓ SHS-2 shredding disc (2 mm).



SAMMIC, S.L. · Basarte, 1  
20720 AZKOITIA (Gipuzkoa) · SPAIN

GOLD SPONSOR

product sheet  
updated 18/11/2025



# COMBI VEGETABLE PREP.-CUTTER CK-24V 2D 120/50-60/1 · 2 DISCS INCLUDED

2-in-1. Compact vegetable slicer + cutter. Adjustable speed with "brushless" technology.



P/N 1050930

## OPTIONAL

- Hub with smooth blades.
- Hub with perforated blades.

## ACCESSORIES

- FCS slicing discs
- FCOS rippled slicing disc
- FMS dicing grid
- FFS chipping grid
- FCES julienne discs
- SHS shredding & grating discs
- Disc and grid packs - Compact Line
- Disc and grid holder

## SPECIFICATIONS

Total loading: 1500 W  
 Electrical supply: 120 V / 50-60 Hz / 1~ (5.3 A)

### As vegetable preparation machine

Hourly production: 50 kg - 350 kg  
 Inlet opening: 89 cm<sup>2</sup>  
 Disc diameter: 180 mm  
 Speed as veg. slicer: 5 (300 rpm - 1000 rpm)  
 External dimensions (W x D x H): 378 mm x 309 mm x 533 mm  
 Net weight (Veg.Pre.): 12.9 kg

### As cutter

Bowl capacity: 4.4 l  
 Speeds as cutter (positions): 10 (300 rpm - 3000 rpm)  
 External dimensions (W x D x H): 252 mm x 309 mm x 434 mm  
 Net weight (Cutter): 11.9 kg  
 Crated dimensions  
 382 x 563 x 480 mm  
 Volume Packed: 0.1 m<sup>3</sup>  
 Gross weight: 18.5 kg

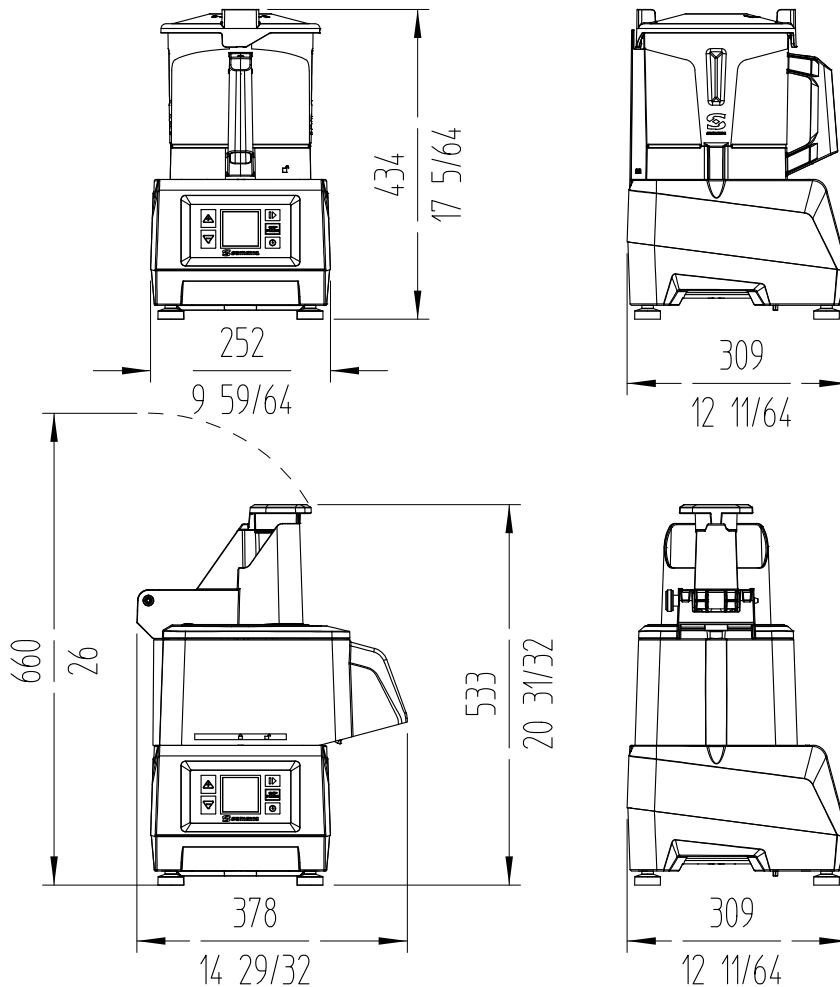

DYNAMIC PREPARATION  
FOOD PROCESSOR / VEG PREP COMBI MACHINES

**sammic** | sammic.com  
 Food Service Equipment Manufacturer

Polígono Basarte, 1. phone +34 943 15 72 36  
 20720 Azkoitia, Spain sales@sammic.com



Project	Date
Item	Qty
Approved	

product sheet  
updated 18/11/2025