



# CUTTER-EMULSIFIER KE-8V 120/50-60/1

Bowl capacity: 8 l. Adjustable speed with “brushless” technology.



P/N 1050855



DYNAMIC PREPARATION  
CUTTER-MIXERS & EMULSIFIERS

## SALES DESCRIPTION

- ✓ ULTRA Heavy Duty line. Adjustable speed motor block + 8 l cutter bowl with toothed blades and “cut&mix” scraper.
- ✓ To cut, grind, texturize, mix and knead any food in seconds.
- ✓ Ideal for emulsions and texturizations.
- ✓ Brushless technology: maximum efficiency.

### Equipped with “brushless” technology: powerful and efficient motors.

- ✓ Maximum efficiency: maintain the torque throughout the speed range.
- ✓ Exclusive “Force control system”: guarantee of a uniform and high quality result.
- ✓ Lightweight and compact design: they weigh less, they occupy less space.
- ✓ Improved air/water-tightness since no ventilation is required.
- ✓ They generate less noise: improved workplace environment.

### Efficiency and performance

- ✓ Possibility of programming by time and pulse button.
- ✓ Reverse function, ideal for mixing products instead of cutting.
- ✓ 8 litre stainless steel hopper.
- ✓ Transparent lid with built-in “cut&mix” mixer.
- ✓ Depending on the purpose, the possibility of using optional smooth or perforated blades.
- ✓ Built-in parametrisable programs to obtain the desired texture in seconds and in a standardized way: dense texture, fine texture, pulses (PrecisePulse function).
- ✓ Option to customize programs for recipe standardization.

### Built to last

- ✓ Robust construction of stainless steel and food-grade materials of the highest quality: stainless steel motor block with aluminium lid.

- ✓ Stainless steel hopper with highly-resistant lid.

### Maximum comfort for the user

- ✓ Advanced control panel that is very intuitive to use and offers all the information at a glance.

### Maintenance, safety, hygiene

- ✓ Safety microswitches on the hopper and lid position.
- ✓ Appliance certified by NSF International (regulations on hygiene, cleaning and materials suitable for contact with foods).
- ✓ 100% tested.

## INCLUDES

- ✓ Set of serrated blades.
- ✓ “Cut&mix” scraper.

## OPTIONAL

- Smooth blades.
- Perforated blades.

## ACCESSORIES

- Blades for CK / K / KE
- “Cut&mix” scrapers CK / K / KE

## SPECIFICATIONS

Electrical supply: 120 V / 60 Hz / 1~ (15 A)

Plug: USA (NEMA 5-15P / 2P+G)

Bowl capacity: 8 l

Bowl dimensions: Ø240 mm x 199 mm

Total loading: 2200 W

Speed, min-max: 300 rpm - 3000 rpm

### External dimensions (W x D x H)

✓ Width: 286 mm

✓ Depth: 387 mm

✓ Height: 517 mm

Net weight: 18.9 kg

Crated dimensions

440 x 355 x 570 mm

Volume Packed: 0.09 m<sup>3</sup>

Gross weight: 24.6 kg



**IDDSI**  
International Dysphagia Diet  
Standardisation Initiative

GOLD SPONSOR



# CUTTER-EMULSIFIER KE-8V 120/50-60/1

Bowl capacity: 8 l. Adjustable speed with "brushless" technology.



P/N 1050855

DYNAMIC PREPARATION  
CUTTER-MIXERS & EMULSIFIERS

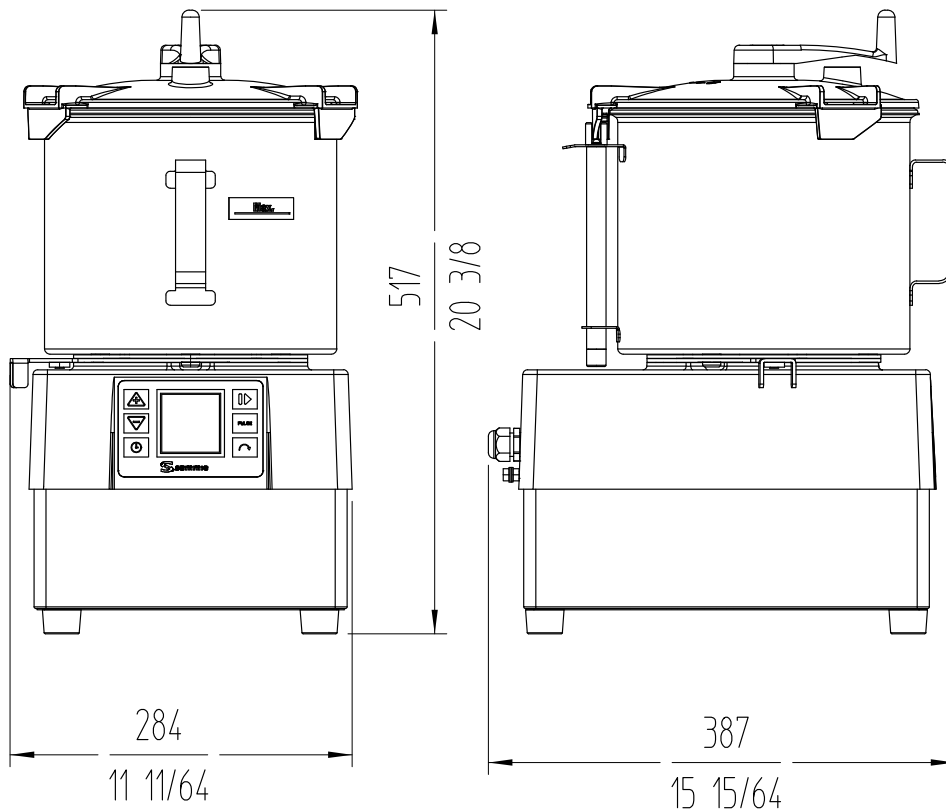

**sammic** | sammic.com  
**Food Service Equipment Manufacturer**

Polígono Basarte, 1. phone +34 943 15 72 36  
 20720 Azkoitia, Spain sales@sammic.com



Project	Date
Item	Qty
Approved	

product sheet  
updated 17/12/2025