



VEGETABLE PREPARATION MACHINE CA-3V 120/50-60/1

Commercial vegetable preparation machine. Production up to 500 kg.



P/N 1050787



DYNAMIC PREPARATION
COMMERCIAL VEGETABLE PREPARATION MACHINES

SALES DESCRIPTION

Variable speed motor block + universal head.
Equipped with “brushless” technology.

Equipped with “brushless” technology: powerful and efficient motors.

- ✓ Maximum efficiency: maintain the torque throughout the speed range.
- ✓ Exclusive “force control system”: guarantee of a uniform and high quality cut.
- ✓ Lightweight and compact design: they weigh less, they occupy less space.
- ✓ Improved air/water-tightness since no ventilation is required.
- ✓ They generate less noise: improved workplace environment.

A perfect cut

- ✓ High precision adjustments to obtain a uniform and excellent-quality cut.
- ✓ It can be fitted with a wide range of discs and grids of the highest cutting quality. Combining these accessories together to obtain more than 70 different types of cuts and grating grades.
- ✓ Exclusive “Force Control System” to optimise and standardise the cutting of each product: acoustic warning when the motor exceeds the pre-established force.

Built to last

- ✓ Made from stainless steel and food-grade materials of the highest quality: stainless steel motor block and food-grade aluminium head.

Maximum comfort for the user

- ✓ Ergonomic design: product sliced in one single movement.
- ✓ Lateral product output: requires less space on the worktop and guides the product, avoiding splashes.
- ✓ Advanced control panel that is very intuitive to use and offers all the information at a glance.

Maintenance, safety, hygiene

- ✓ Lever and lid easily removable for cleaning purposes.
- ✓ Combination of safety systems: head, cover, power switch.

- ✓ Appliance certified by NSF International (regulations on hygiene, cleaning and materials suitable for contact with foods).
- ✓ 100% tested.

INCLUDES

- ✓ Variable speed motor block.
- ✓ Universal head.
- ✓ Universal grid cleaner QC-U.

OPTIONAL

- Tube head for long products.
- Support-trolley.
- Discs and grids.
- Grid cleaning kit.
- Cutter bowl.

ACCESSORIES

- FCC curved slicing discs
- FCO rippled slicing discs
- FFC chipping grids
- FMC dicing grids
- FCE julienne discs
- Long vegetable attachment
- Disc and grid packs - Heavy Duty
- Disc and grid holder
- Stand-trolley
- Quick Cleaner: grid cleaners
- FC slicing discs
- SH shredding & grating discs
- Déli-cut cutting kit - Heavy Duty
- Universal grid cleaner QC-U

SPECIFICATIONS

Hourly production: 500 kg
 Inlet opening: 136 cm²
 Disc diameter: 205 mm
 Speed as veg. slicer: 300 rpm - 1000 rpm
 Electrical supply: 120 V / 60 Hz / 1~ (15 A)
 Plug: USA (NEMA 5-15P / 2P+G)

External dimensions (W x D x H)

Width: 391 mm
 Depth: 409 mm
 Height: 552 mm
 Net weight: 24 kg
 Crated dimensions
 435 x 430 x 600 mm
 Volume Packed: 0.11 m³
 Gross weight: 28 kg



SAMMIC, S.L. · Basarte, 1
20720 AZKOITIA (Gipuzkoa) · SPAIN

product sheet
updated 07/11/2025



VEGETABLE PREPARATION MACHINE CA-3V 120/50-60/1

Commercial vegetable preparation machine. Production up to 500 kg.



P/N 1050787

DYNAMIC PREPARATION
COMMERCIAL VEGETABLE PREPARATION MACHINES

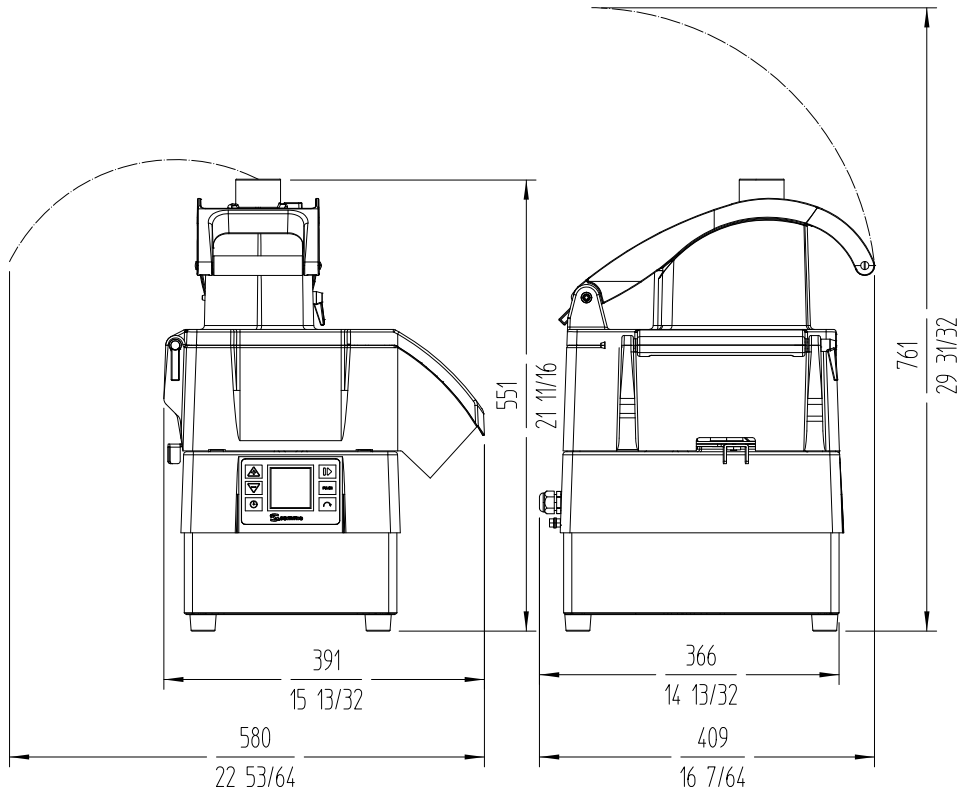

sammic | sammic.com
Food Service Equipment Manufacturer

Polígono Basarte, 1. phone +34 943 15 72 36
 20720 Azkoitia, Spain sales@sammic.com



| | |
|----------|------|
| Project | Date |
| Item | Qty |
| Approved | |

product sheet
updated 07/11/2025