



# IMMERSION BLENDER & WHISK COMBO MB-21 120/50-60/1 USA

Professional hand blender and beater. 300 W.



P/N 3030764

✓ Approved by NSF: guaranteed safety and hygiene.

## INCLUDES

- ✓ Variable speed motor block.
- ✓ Whisk BA-20.
- ✓ MA-21 mixer arm.
- ✓ Wall mount.

## OPTIONAL

- MA-22 mixer arm.

## SPECIFICATIONS

Total loading: 300 W  
 Electrical supply: 120 V / 50-60 Hz / 1~ (2.6 A)  
 Plug: USA (NEMA 5-15P / 2P+G)

### Liquidiser function

Maximum recipient capacity: 12 l  
 Maximum working depth: 169 mm  
 Motor speed: 1500 - 15000 rpm  
 Blade diameter: 50 mm  
 Blade guard diameter: 82 mm  
 Liquidising arm length: 250 mm  
 Total length: 514 mm

### Whisk function

Motor speed: 200 - 800 rpm  
 Capacity (egg whites): 2 - 30  
 Revolving arm length: 306 mm  
 Total length (with revolving arm): 570 mm  
 Net weight: 3.2 kg  
 Noise level (1m.): <80 dB(A)  
 Crated dimensions  
 440 x 375 x 105 mm  
 Gross weight: 3.8 kg



## SALES DESCRIPTION

- ✓ Variable speed motor block.
- ✓ 250 mm detachable mixer arm designed for continuous use in recipients of up to 12 l.
- ✓ Whisk with capacity for 2 to 30 egg whites.

### All-in-one

- ✓ Professional hand blender and beater.
- ✓ Professional hand blender designed for carrying out different preparations without the need for add-on tools.
- ✓ Professional Y-blade, made from tempered steel and with a long-duration cutting edge.
- ✓ Vario-speed: variable speed.
- ✓ Mixer arm designed to work in recipients of up to 12 l.
- ✓ Beater with capacity for 2 to 30 egg whites.

### Maximum comfort for the user

- ✓ Compact design: logical and manageable size.
- ✓ Ergo-design & bi-mat-grip: external casing made in two materials for an ergonomic hold. Anti-slip grip. Optimum inclination of handle, minimising fatigue.
- ✓ Click-on-arm: detachable arm with fast and secure closure.
- ✓ Mixer arm hood designed to avoid splashes.
- ✓ Intuitive use: very simple operation. Warning light when the machine is connected to the mains.

### Built to last

- ✓ Professional performance: capable of carrying out prolonged work without the casing overheating.
- ✓ Life-plus: equipped with a motor which has passed all of the most demanding usage tests.
- ✓ Studied geometry: casing designed to avoid rolling and falling.
- ✓ Ultra-durable arms designed to stand high temperatures in operation.
- ✓ Easy to clean: detachable, dishwasher safe arms. The whisks are detachable and dishwasher safe.

DYNAMIC PREPARATION  
COMMERCIAL HAND BLENDERS

product sheet  
updated 26/02/2025





# IMMERSION BLENDER & WHISK COMBO MB-21 120/50-60/1 USA

Professional hand blender and beater. 300 W.



P/N 3030764

DYNAMIC PREPARATION  
COMMERCIAL HAND BLENDERS

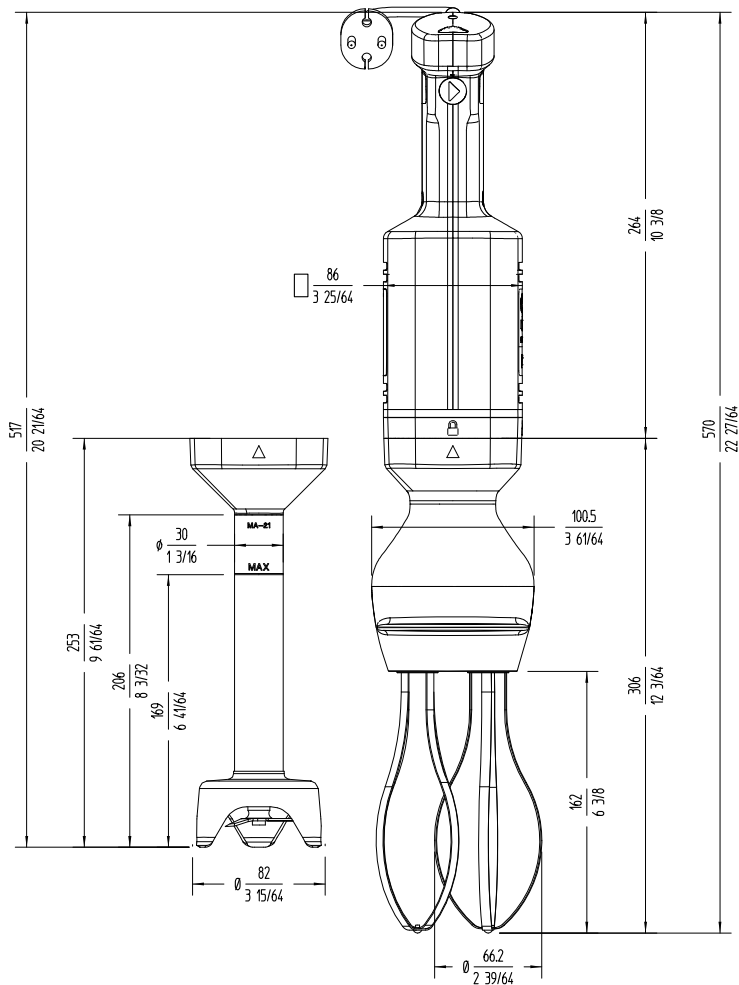

**sammic** | www.sammic.com  
Food Service Equipment Manufacturer

Polígono Basarte, 1. phone +34 943 15 72 36  
20720 Azkoitia, Spain sales@sammic.com



Project \_\_\_\_\_ Date \_\_\_\_\_

Item \_\_\_\_\_ Qty \_\_\_\_\_

Approved \_\_\_\_\_

product sheet  
updated 26/02/2025