



VEGETABLE PREPARATION MACHINE CA-61 120/60/1

High-production commercial vegetable processor, up to 1000 kg.



P/N 1050741



DYNAMIC PREPARATION
COMMERCIAL VEGETABLE PREPARATION MACHINES

SALES DESCRIPTION

Single-speed motor block + high-production semi-automatic hopper.

A perfect cut

- ✓ High precision adjustments to obtain a uniform and excellent-quality cut.
- ✓ It can be fitted with a wide range of discs and grids of the highest cutting quality.
- ✓ Combining these accessories together to obtain more than 70 different types of cuts and grating grades.
- ✓ Head equipped with high ejector: enables a higher quantity of product to be shifted.

Built to last

- ✓ Made from stainless steel and materials of the highest quality and suitable for food contact: stainless steel motor block and hopper and food-grade aluminium head.
- ✓ High power asynchronous motor.

Maximum comfort for the user

- ✓ Ergonomic design. Maximum comfort for the user.
- ✓ Lateral product output: requires less space on the worktop and guides the product, avoiding splashes.
- ✓ The electronic command panel is very intuitive.

Maintenance, safety, hygiene

- ✓ Hopper and lid easily removable for cleaning.
- ✓ Combination of safety systems: hopper, cover, power switch.
- ✓ Appliance certified by NSF International (regulations on hygiene, cleaning and materials suitable for contact with foods).
- ✓ 100% tested.

INCLUDES

- ✓ Single-speed motor block.
- ✓ High production semi-automatic hopper.

OPTIONAL

- Large capacity head.
- Tube head.
- Support-trolley.
- Discs and grids.
- Grid cleaning kit.

ACCESSORIES

- FCC curved slicing discs
- FCO rippled slicing discs
- FFC chipping grids
- FMC dicing grids
- FR shredding & grating discs
- Long vegetable attachment
- Disc and grid packs
- Disc and grid holder
- Stand-trolley
- Large capacity attachment
- Grid cleaning kit
- FC-D slicing discs
- SH shredding & grating discs
- Déli-cut cutting kit - Heavy Duty

SPECIFICATIONS

Hourly production: 500 kg - 1000 kg

Inlet opening: 273 cm²

Disc diameter: 205 mm

Motor speed: 365 rpm

Loading: 1100 W

Electrical supply: 120 V / 60 Hz / 1~ (4.3 A)

Plug: USA (NEMA 5-15P / 2P+G)

Noise level (1m.): <70 dB(A)

Background noise: 32 dB(A)

External dimensions (W x D x H)

Width: 430 mm

Depth: 420 mm

Height: 810 mm

Net weight: 28.5 kg

Crated dimensions

480 x 460 x 740 mm

Volume Packed: 0.17 m³

Gross weight: 33 kg



product sheet
updated 19/01/2024



VEGETABLE PREPARATION MACHINE CA-61 120/60/1

High-production commercial vegetable processor, up to 1000 kg.



P/N 1050741

DYNAMIC PREPARATION
COMMERCIAL VEGETABLE PREPARATION MACHINES

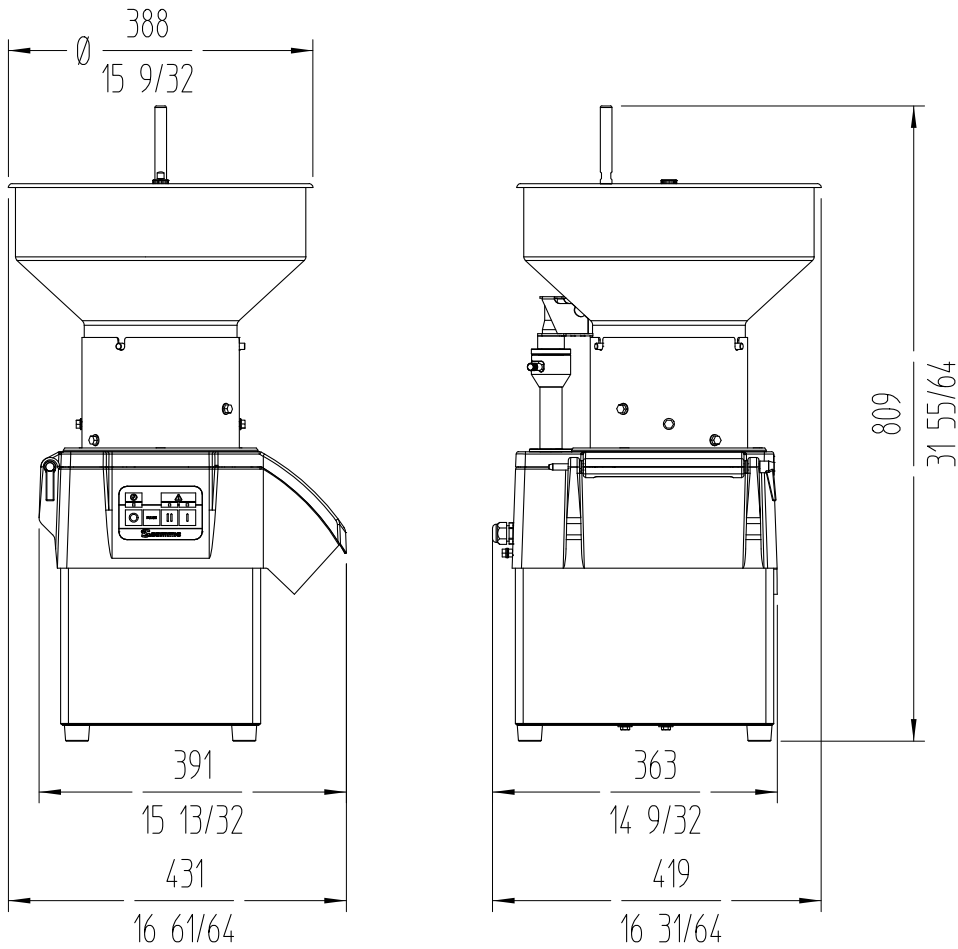

sammic | www.sammic.com
Food Service Equipment Manufacturer

Polígono Basarte, 1. phone +34 943 15 72 36
20720 Azkoitia, Spain sales@sammic.com



Project	Date
Item	Qty
Approved	

product sheet
updated 19/01/2024