



COMBI VEGETABLE PREP.-CUTTER CK-35V 120/50-60/1

2 in 1: vegetable cutter (450 kg) + cutter with 5.5 l bowl.



P/N 1050756

DYNAMIC PREPARATION
FOOD PROCESSOR / VEG PREP COMBI MACHINES



SALES DESCRIPTION

It has a variable speed motor block, universal head and 5.5 l cutter bowl equipped with a rotor with micro-serrated blades. "Brushless" technology.

Equipped with "brushless" technology: powerful and efficient motors.

- ✓ Maximum efficiency: maintain the torque throughout the speed range.
- ✓ Exclusive "force control system": guarantee of a uniform and high quality result.
- ✓ Lightweight and compact design: they weigh less, they occupy less space.
- ✓ Improved air/water-tightness since no ventilation is required.
- ✓ They generate less noise: improved workplace environment.

Cutting function: a perfect cut

- ✓ High precision settings and comprehensive cutter and disc design aimed at obtaining a perfect cut.
- ✓ It can be fitted with a wide range of discs and grids of the highest cutting quality. By combining these accessories, you can achieve more than 70 different types of cuts and grating grades.
- ✓ Exclusive "Force Control System" to optimise and standardise the cutting of each product: acoustic warning when the motor exceeds the pre-established force.

Cutter function: efficiency and performance

- ✓ Possibility of programming by time and pulse button.
- ✓ Reverse function, ideal for mixing products instead of cutting.
- ✓ 5.5 lt stainless steel bowl.
- ✓ Transparent lid with built-in "cut&mix" mixer.
- ✓ Depending on the purpose, the possibility of using optional smooth or perforated blades.
- ✓ Built-in parametrisable programs to obtain the desired texture in seconds and in a standardized way: dense texture, fine texture, pulses (PrecisePulse function).

- ✓ Option to customize programs for recipe standardization.

Built to last

- ✓ Made from stainless steel and food-grade materials of the highest quality: stainless steel motor block and food-grade aluminium head. Stainless steel hopper with highly-resistant lid.

Maximum comfort for the user

- ✓ Ergonomic design: product sliced in one single movement.
- ✓ Lateral product output: it requires less room on the work surface and directs the product avoiding splashing.
- ✓ Advanced control panel that is very intuitive to use and offers all the information at a glance.

Maintenance, safety, hygiene

- ✓ Plunger, lid and bowl easy to remove for changing or cleaning.
- ✓ Combination of security systems: head, covers, bowl, power switch.
- ✓ Appliance certified by NSF International (regulations on hygiene, cleaning and materials suitable for contact with foods).
- ✓ 100% tested.

INCLUDES

- ✓ Variable speed motor block.
- ✓ Universal head.
- ✓ Cutter bowl, with micro-serrated blade rotor.
- ✓ Universal grid cleaner QC-U.

OPTIONAL

- Tube head.
- Discs, grids and disc support.
- Rotor with smooth cutting blades.
- Rotor with perforated cutting blades.
- Support-trolley.
- Grid cleaning kit.

ACCESSORIES

- FCC curved slicing discs
- FCO rippled slicing discs
- FFC chipping grids
- FMC dicing grids
- FCE julienne discs
- FR shredding & grating discs
- Disc and grid packs - Heavy Duty
- Disc and grid holder
- Blades for CK / K / KE
- Quick Cleaner: grid cleaners
- FC-D slicing discs
- SH shredding & grating discs

SPECIFICATIONS

Total loading: 1500 W

Electrical supply: 120 V / 60 Hz / 1~ (15 A)

Plug: USA (NEMA 5-15P / 2P+G)

As vegetable preparation machine

Hourly production: 100 kg - 450 kg

Inlet opening: 136 cm²

Disc diameter: 205 mm

Speed as veg. slicer: 300 rpm - 1000 rpm

External dimensions (W x D x H): 391 mm x 409 mm x 552 mm

Net weight (Veg.Pre.): 24 kg

As cutter

Bowl capacity: 5.5 l

Speeds as cutter (positions): 300 rpm - 3000 rpm

External dimensions (W x D x H): 286 mm x 387 mm x 487 mm

Net weight (Cutter): 18 kg

Noise level (1m.): <70 dB(A)



product sheet
updated 03/02/2025



COMBI VEGETABLE PREP.-CUTTER CK-35V 120/50-60/1

2 in 1: vegetable cutter (450 kg) + cutter with 5.5 l bowl.



P/N 1050756

Background noise: 32 dB(A)
Crated dimensions
705 x 415 x 515 mm

Volume Packed: 0.15 m³
Gross weight: 31.8 kg

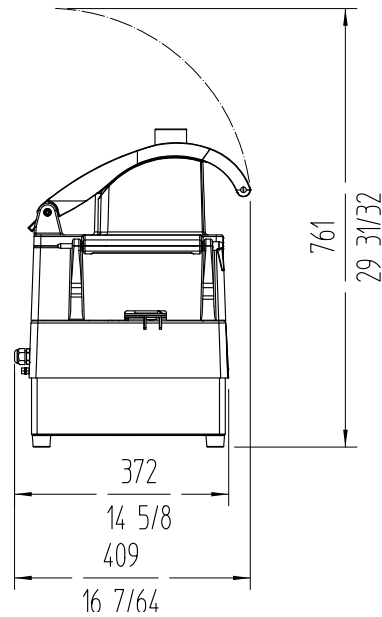
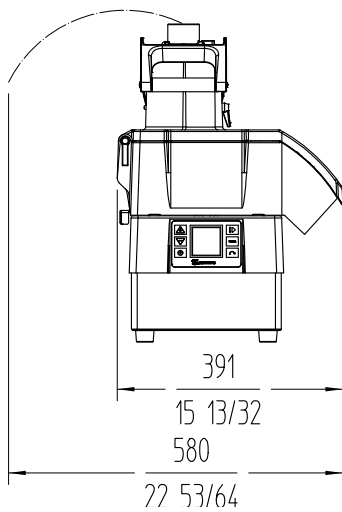
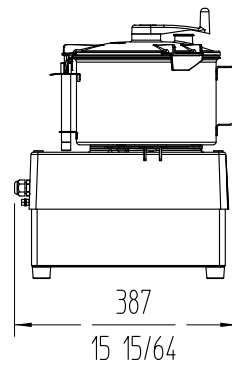
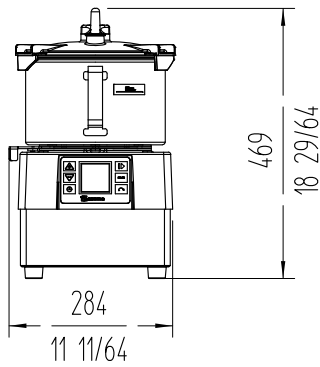

DYNAMIC PREPARATION
FOOD PROCESSOR / VEG PREP COMBI MACHINES

sammic | www.sammic.com
Food Service Equipment Manufacturer

Polígono Basarte, 1. phone +34 943 15 72 36
20720 Azkoitia, Spain sales@sammic.com



Project	Date
Item	Qty
Approved	

product sheet
updated 03/02/2025