



IMMERSION BLENDER XM-52 120/50-60/1 USA

Professional immersion blender. 570 W.



P/N 3030841



DYNAMIC PREPARATION
COMMERCIAL HAND BLENDERS

SALES DESCRIPTION

- ✓ Fixed speed motor block.
- ✓ 525 mm detachable arm.
- ✓ Designed for continuous use in recipients of up to 120 l.

All-in-one

- ✓ Professional hand blender designed for carrying out different preparations without the need for add-on tools.
- ✓ Professional Y-blade, made from tempered steel and with a long-duration cutting edge.
- ✓ Fixed speed.
- ✓ Designed to work in recipients of up to 120 l.

Exclusive TiltStop system

- ✓ Your hand blender will stop in case of a fall or excessive tilt from the vertical position.
- ✓ Moreover, it won't initiate unless it's in the correct usage position.
- ✓ This ensures optimal operation and increases the operator's safety at the workplace.

Maximum comfort for the user

- ✓ Compact design: logical and manageable size.
- ✓ Ergo-design & bi-mat-grip: external casing made in two materials for an ergonomic hold. Anti-slip grip. Optimum inclination of handle, minimising fatigue.
- ✓ Click-on-arm: detachable arm with fast and secure closure.
- ✓ Hood designed to avoid splashes.
- ✓ Intuitive use: very simple operation. LED warning light in two colours to indicate the status of the machine.
- ✓ Possibility of continuous operation.

Built to last

- ✓ Professional performance: capable of carrying out prolonged work without the casing overheating.

- ✓ Life-plus: equipped with a motor which has passed all of the most demanding usage tests.
- ✓ Studied geometry: casing designed to avoid rolling and falling.
- ✓ Ultra-durable arms designed to stand high temperatures in operation.
- ✓ Easy to clean: the arm can be washed under the tap or in the dishwasher.
- ✓ Approved by NSF: guaranteed safety and hygiene.

INCLUDES

- ✓ Fixed speed motor block.
- ✓ MA-52 mixer arm.
- ✓ Wall mount.

OPTIONAL

- MA-51 mixer arm.
- "Quick fix" clamp.
- Clamp sliding frame.

ACCESSORIES

- Clamp sliding frame
- Mixer arms MA-50
- Motor unit MM-50
- Quick-Fix bowl clamp

SPECIFICATIONS

Total loading: 720 W
 Maximum recipient capacity: 120 l
 Maximum working depth: 350 mm
 Motor speed: 12000 rpm
 Blade diameter: 60 mm
 Blade guard diameter: 101 mm
 Electrical supply: 120 V / 50-60 Hz / 1~ (4.1 A)
 Plug: USA (NEMA 5-15P / 2P+G)

Length

Liquidising arm length: 525 mm
 Total length: 865 mm
 Net weight: 4.85 kg
 Noise level (1m.): <80 dB(A)
 Crated dimensions
 575 x 455 x 130 mm
 Gross weight: 6.37 kg



IDDSI
 International Dysphagia Diet
 Standardisation Initiative



IMMERSION BLENDER XM-52 120/50-60/1 USA

Professional immersion blender. 570 W.



P/N 3030841

DYNAMIC PREPARATION
COMMERCIAL HAND BLENDERS

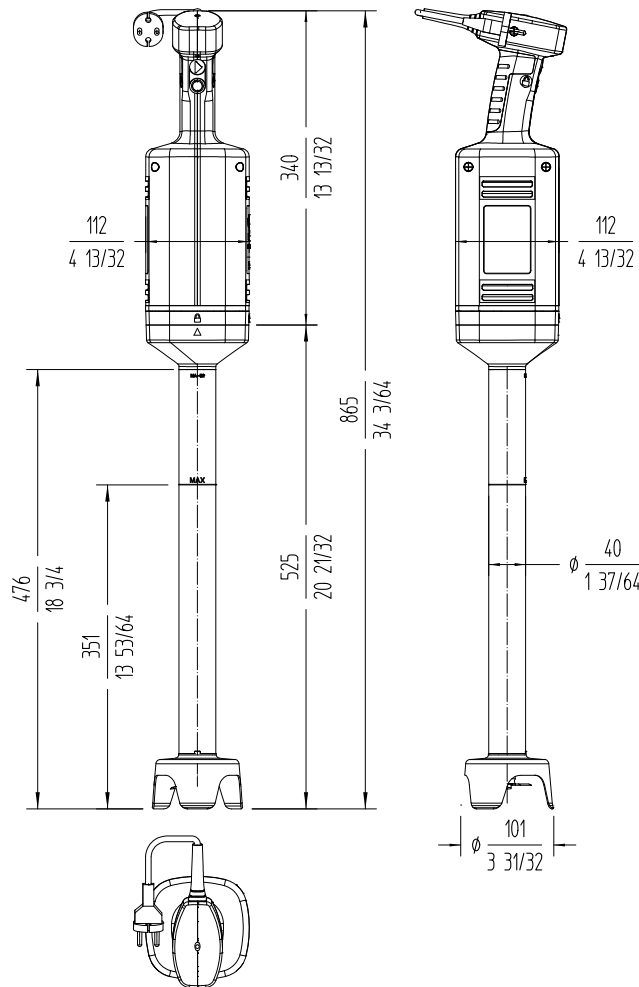

sammic | sammic.com
Food Service Equipment Manufacturer

Polígono Basarte, 1. phone +34 943 15 72 36
 20720 Azkoitia, Spain sales@sammic.com



Project	Date
Item	Qty
Approved	

product sheet
updated 03/12/2025