



VEGETABLE PREPARATION MACHINE CA-21 2D 120/60/1 · 2 DISCS INCLUDED

Compact vegetable preparation machine. 1-speed vegetable slicer.



P/N 1050954



DYNAMIC PREPARATION
COMMERCIAL VEGETABLE PREPARATION MACHINES

SALES DESCRIPTION

Compact ACTIVE line.
1-speed motor block + vegetable slicer attachment.

A perfect cut

- ✓ High-precision settings ensure a uniform cut of outstanding quality.
- ✓ Gravity Slide System: Gravity product expulsion ramp allow to reconstruct the sliced product for storing or presentation purpose.
- ✓ Ejection disc included for the products that require its use.
- ✓ Can be fitted with a wide range of discs and grids of the highest cutting quality.
- ✓ By combining these accessories, more than 35 different types of cuts and gratings can be achieved.
- ✓ Possibility of extending its functionality by adding the cutter bowl with blades.

Built to last

- ✓ Sturdy construction in food-grade best quality materials.
- ✓ High power asynchronous motor.

Maximum comfort for the user

- ✓ Ergonomic design: product sliced in one single movement.
- ✓ Lateral product output: requires less space on the worktop and guides the product, avoiding splashes.
- ✓ Adjustable product ejection direction to adapt to the workflow in the preparation area.
- ✓ Recessed cored relief allows for any position in the kitchen, side walls, back wall, light and compact, this machine can fit.
- ✓ The electronic control panel is extremely simple to operate.

Maintenance, safety, hygiene

- ✓ Lever and lid easily removable for cleaning purposes.
- ✓ Stainless steel, dishwasher-safe discs. The removable blades allow for an even more thorough and efficient cleaning.
- ✓ Combination of safety systems: head, cover, power switch.
- ✓ Complete error warning system.
- ✓ Appliance certified by NSF International (regulations on hygiene, cleaning and materials suitable for contact with foods).
- ✓ 100% tested.

INCLUDES

- ✓ 1-speed motor block.
- ✓ Vegetable slicer attachment.
- ✓ Gravity product expulsion ramp.
- ✓ Ejection disc.
- ✓ FCS-4 slicing disc (4 mm).
- ✓ SHS-2 shredding disc (2 mm).

OPTIONAL

- Cutter bowl.
- Hub with toothed blades.
- Hub with smooth blades.
- Hub with perforated blades.

ACCESSORIES

- Cutter bowl
- FCS slicing discs
- FCOS rippled slicing disc
- FMS dicing grid
- FFS chipping grid
- FCES julienne discs
- SHS shredding & grating discs
- Hubs with blades
- Disc and grid packs - Compact Line
- Déli-cut cutting kit - Compact Line
- Universal grid cleaner QC-U
- Inner collection container for delicate cuts
- Disc and grid holder

SPECIFICATIONS

Hourly production: 50 kg - 350 kg

Inlet opening: 89 cm²

Disc diameter: 180 mm

Motor speed: 1800 rpm

Loading

Total loading: 1100 W

Electrical supply: 120 V / 60 Hz / 1~ (4 A)

Noise level (1m.): <70 dB(A)

Background noise: 32 dB(A)

External dimensions (W x D x H)

Width: 378 mm

Depth: 309 mm

Height: 533 mm

Net weight: 15.2 kg

Crated dimensions

382 x 563 x 480 mm

Volume Packed: 0.8 m³

Gross weight: 19.5 kg



SAMMIC, S.L. · Basarte, 1
20720 AZKOITIA (Gipuzkoa) · SPAIN

product sheet
updated 17/12/2025



VEGETABLE PREPARATION MACHINE CA-21 2D 120/60/1 · 2 DISCS INCLUDED

Compact vegetable preparation machine. 1-speed vegetable slicer.



P/N 1050954

DYNAMIC PREPARATION
COMMERCIAL VEGETABLE PREPARATION MACHINES

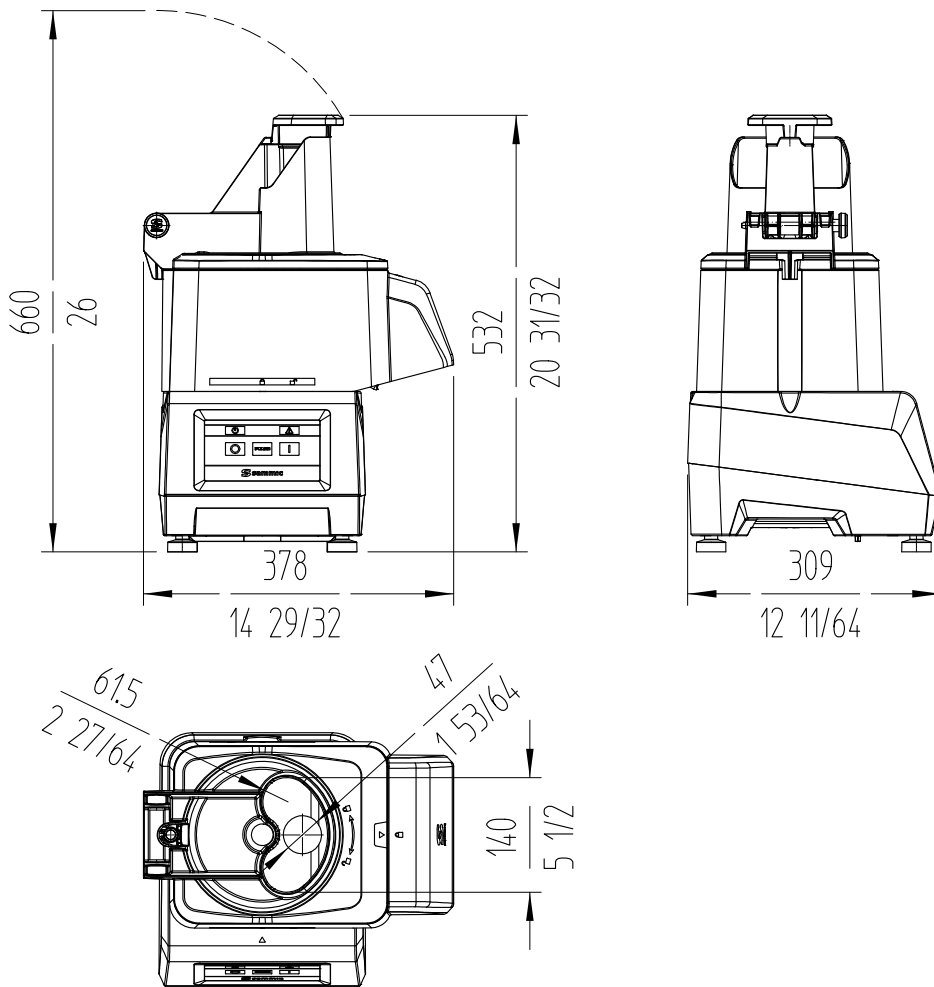

sammic | sammic.com
Food Service Equipment Manufacturer

Polígono Basarte, 1. phone +34 943 15 72 36
20720 Azkoitia, Spain sales@sammic.com



Project	Date
Item	Qty
Approved	

product sheet
updated 17/12/2025